

Ports Configuration

Compact

The below numbers should be used inside the Configurator when using one of the ports on the Compact:

- **RS-232 (DB9)**: use 0.
- **USB**: use 10.

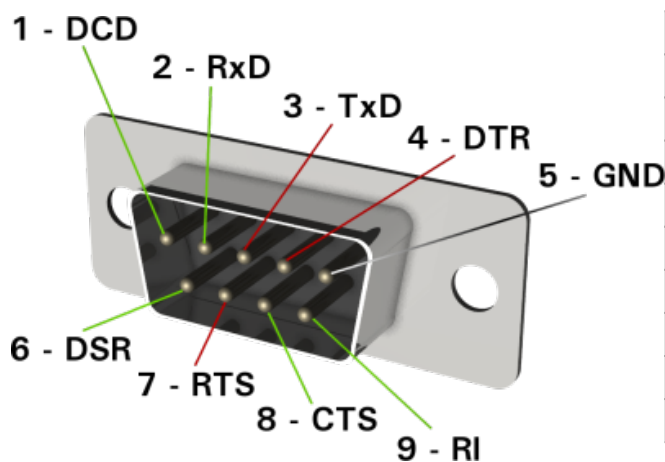

Pin	Signal	Name	Type
1	DCD	Data Carrier Detect	Input
2	RxD	Receive Data	Input
3	TxD	Transmit Data	Output
4	DTR	Data Terminal Ready	Output
5	GND	Signal Ground	-
6	DSR	Data Set Ready	Input
7	RTS	Request to Send	Output
8	CTS	Clear to Send	Input
9	RI	Ring Indicator	Input

Compact's DB9 Serial Port

Rack

The below numbers should be used inside the Configurator when using one of the ports on the Rack:

- **RS-232 (DB9) x2**: use 0 and 1.
- **Additional green ports (RS-232 and RS-485)**: use 2 and 3.
- **USB**: use 10.

The additional green ports on the Rack can be used either for RS-232 or RS-485. Consult the picture below for a proper connection.

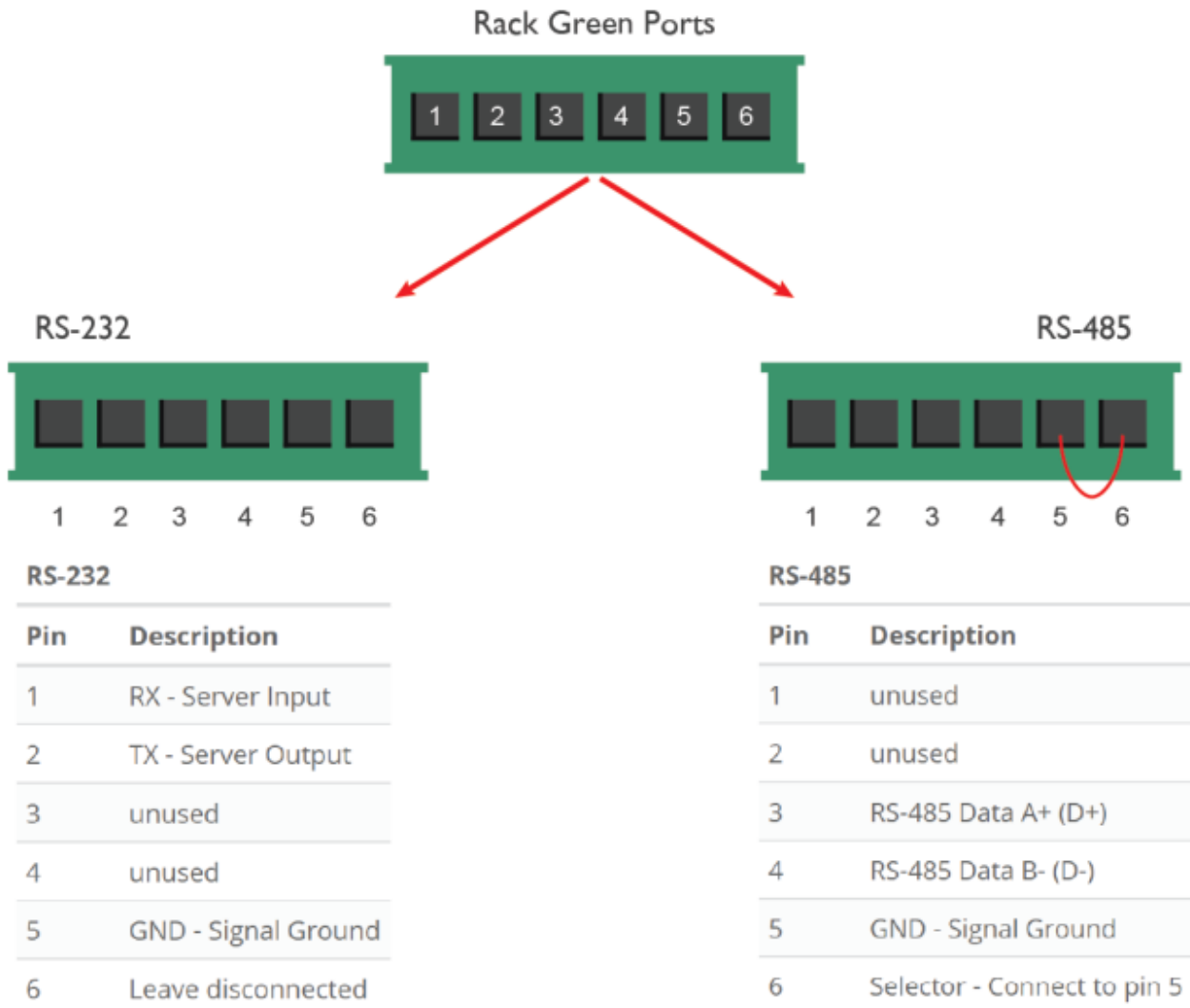

Rack's Green Ports

Brickbox

The below numbers should be used inside the Configurator when using one of the ports on the Brickbox:

- **RS-232:** use 4.
- **RS-485:** use 5.

Brickbox's Ports

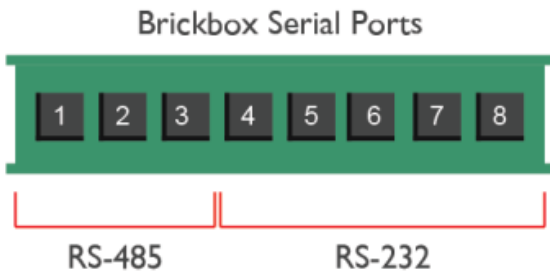

RS-485		RS-232	
Pin	Description	Pin	Description
1	GND - Ground	4	GND - Ground
2	Data A (D+)	5	CTS - Clear To Send (input)
3	Data B (D-)	6	RTS - Request To Send (output)
		7	RX - Receive Data (input)
		8	TX - Transmit Data (output)

Envision_20

The below numbers should be used inside the Configurator when using one of the ports on the Envision_20:

- **RS-232:** use 1.
- **RS-485:** use 2.
- **USB:** use 10.

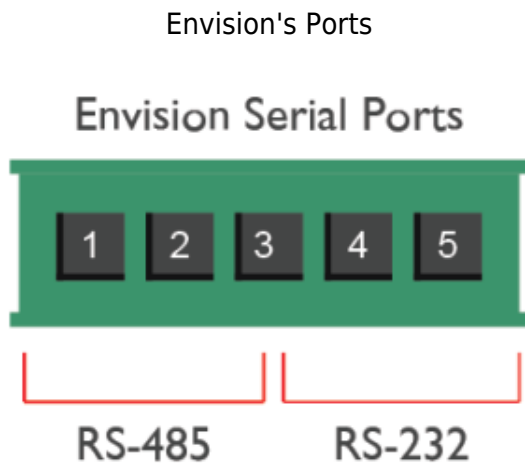

RS-485		RS-232	
Pin	Description	Pin	Description
1	Data A (D+)	3	GND - Ground
2	Data B (D-)	4	TX - Transmit Data (output)
		5	RX - Receive Data (input)

Compact_20

The below numbers should be used inside the Configurator when using one of the ports on the Compact_20:

- **RS-232:** use 4.
- **RS-485:** use 5.
- **USB:** use 10.

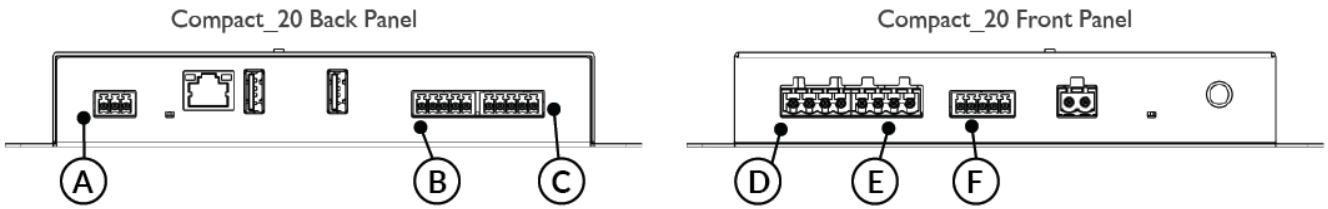

Compact_20 Front/Back Panels

Compact_20 RS-485

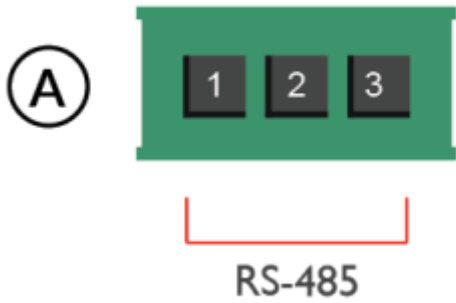

RS-485	
Pin	Description
1	Data A (D+)
2	Data B (D-)
3	GND - Ground

Compact_20 RS-232 + Digital Inputs

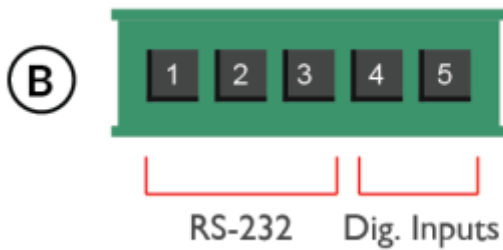

RS-232		Dig. Inputs	
Pin	Description	Pin	Description
1	GND - Ground	4	Digital IN1
2	RX - Receive Data (IN)	5	Digital IN2
3	TX - Transmit Data (OUT)		

Compact_20 Analog/Digital Inputs



Analog/Digital Inputs	
Pin	Description
1	Input 1
2	Input 2
3	Input 3
4	Input 4
5	Input - GND

Compact_20 Relays 1-2

Relays 1-2	
Pin	Description
1	Common R1
2	Relay 1 (N.O.)

D



Relays 1-2 (6A)

Relays 1-2	
Pin	Description
3	Common R2
4	Relay 2 (N.O.)

Compact_20 Relays 3-4

E



Relays 3-4 (6A)

Relays 3-4	
Pin	Description
1	Common R3
2	Relay 3 (N.O.)
3	Common R4
4	Relay 4 (N.O.)

Compact_20 Digital Outputs

F

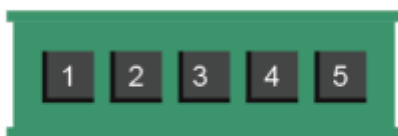

Dig. Outputs (open collector)

Digital Outputs (open collector)	
Pin	Description
1	Supply
2	Output 1
3	Output 2
4	Output 3
5	GND - Ground

Micro_20

The below numbers should be used inside the Configurator when using one of the ports on the Micro_20:

- **USB:** use 10.

Examples

Connecting a DCE device with DB9

A DCE device usually has the pins TX and RX inverted (TX on pin 2, RX on pin 3).

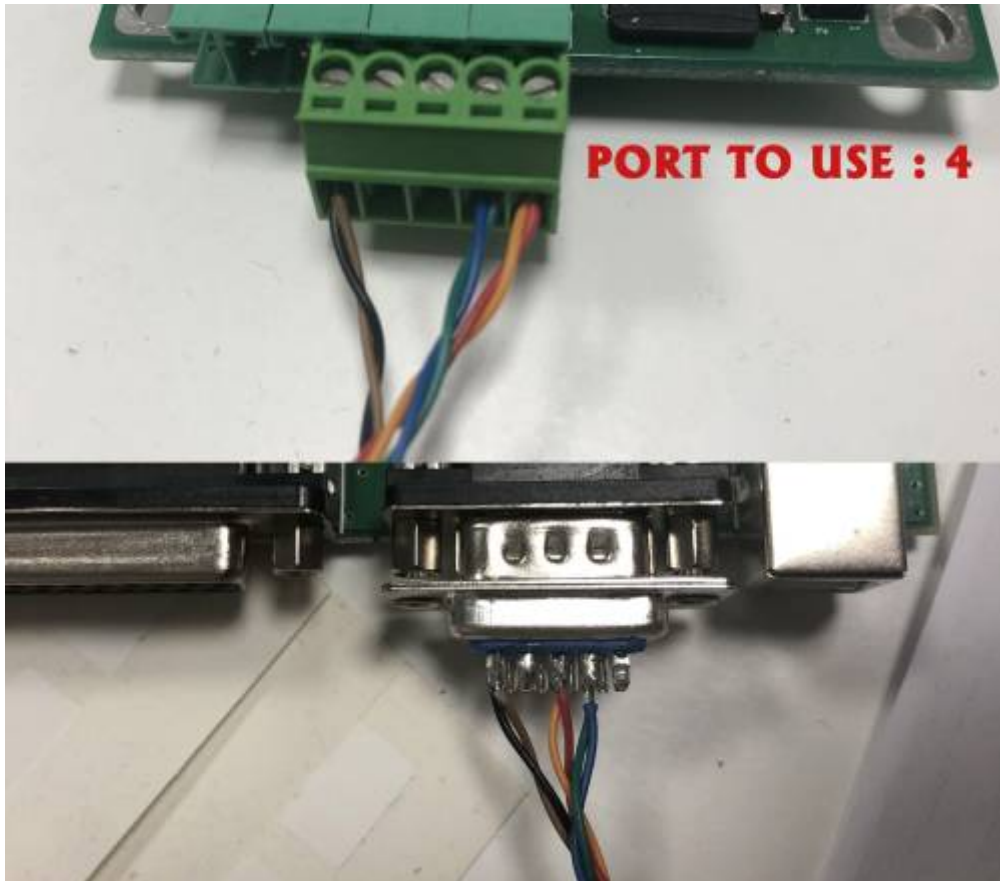

Connecting Brickbox to Paradox DB9 port

Transforming a green block into DB9

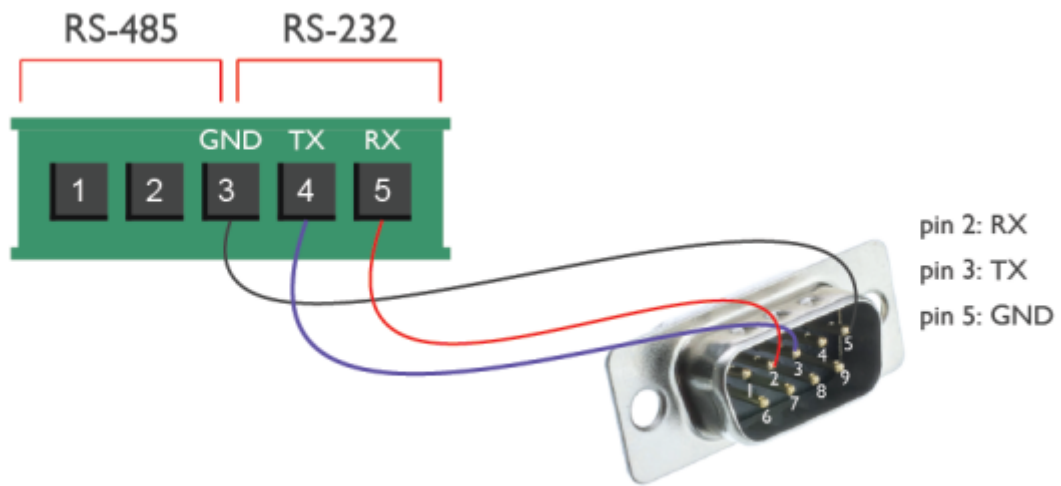

Transforming Envision port to DB9 port

From:
<http://www.thinknx.com/wiki/> - **Learning Thinknx**

Permanent link:
http://www.thinknx.com/wiki/doku.php?id=port_numbers

Last update: **2023/10/12 13:16**

